

PART NUMBER
M5B-18

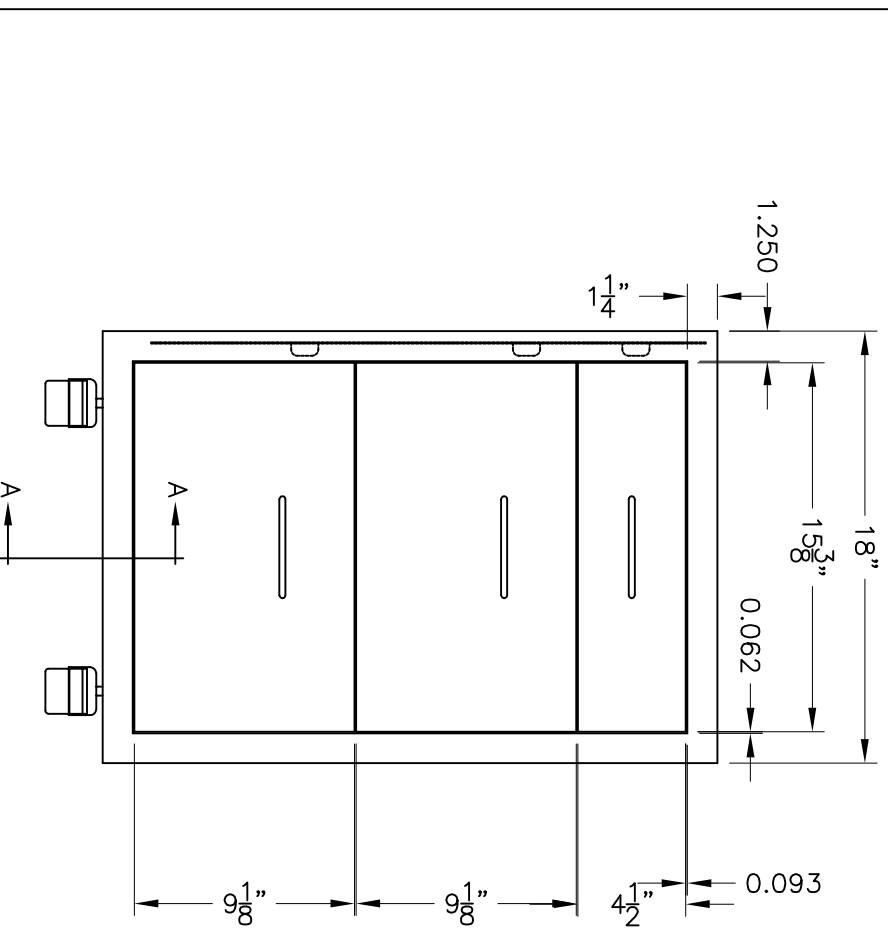

WARNING
 WEIGHT LIMIT PER DRAWER
 MAXIMUM 25 POUNDS
 CAUTION ONE DRAWER OPEN AT A TIME
 EXCEEDING WEIGHT LIMIT COULD CAUSE TIPPING

Label Detail

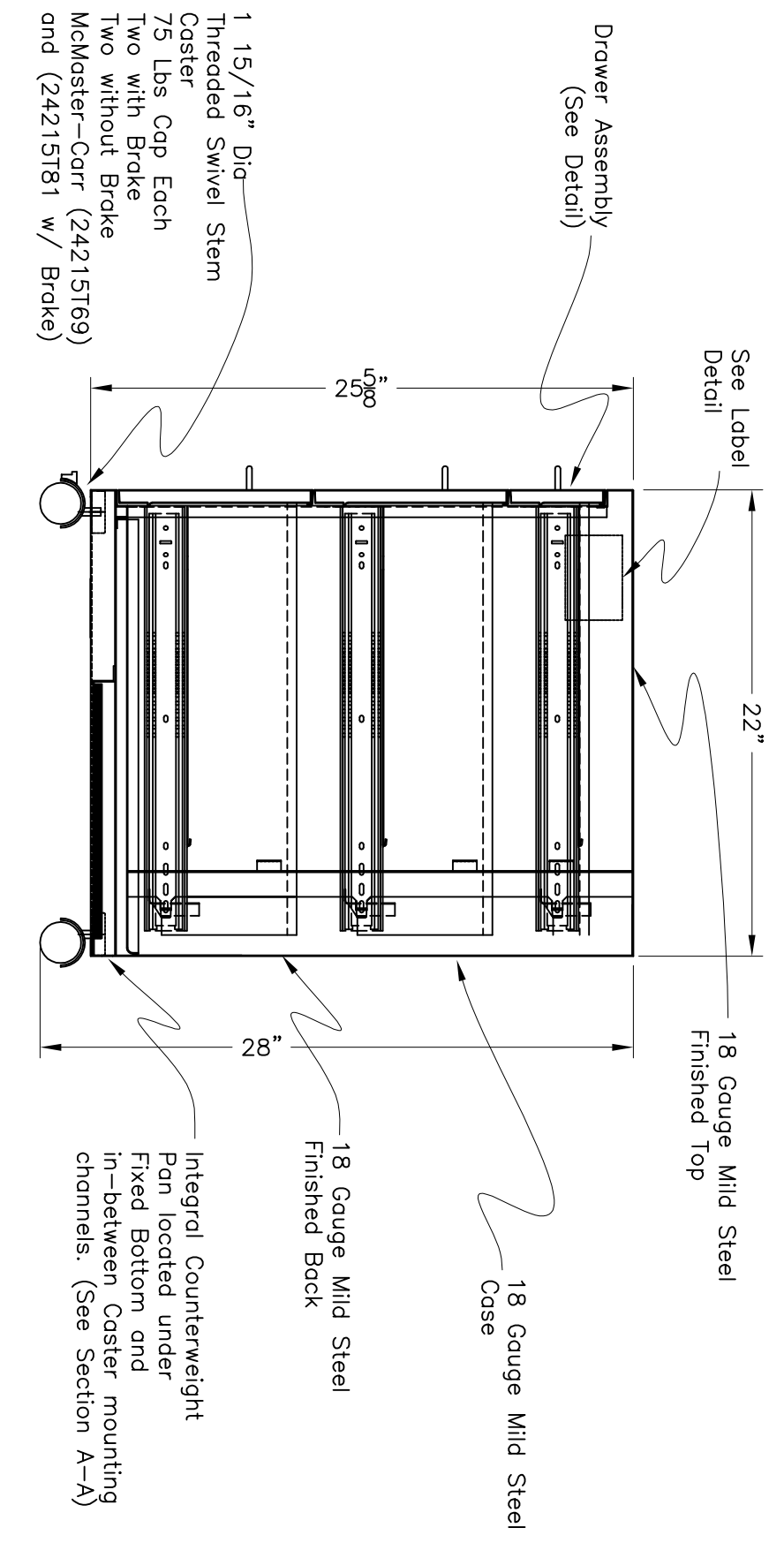

Integral Counterweight Pan located under Fixed Bottom and in-between Caster mounting channels. (See Section A-A)