

PART NUMBER

M2A-24

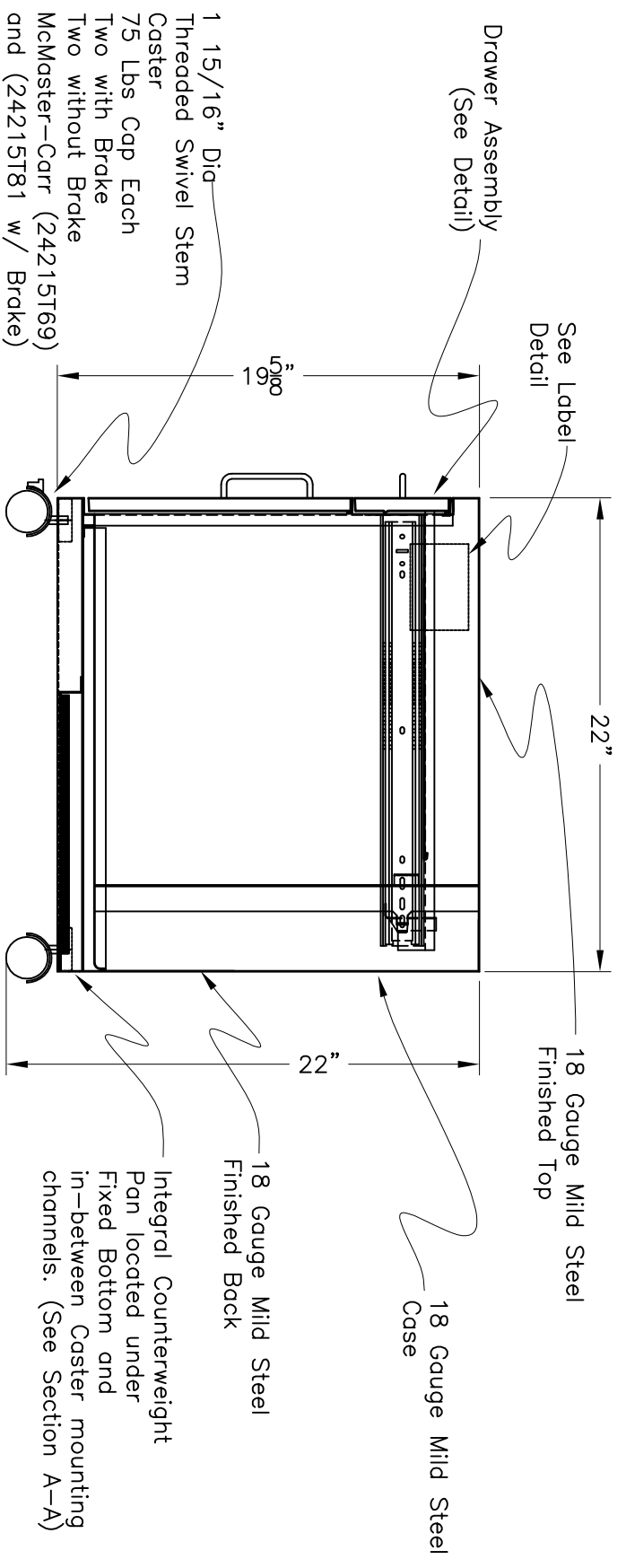
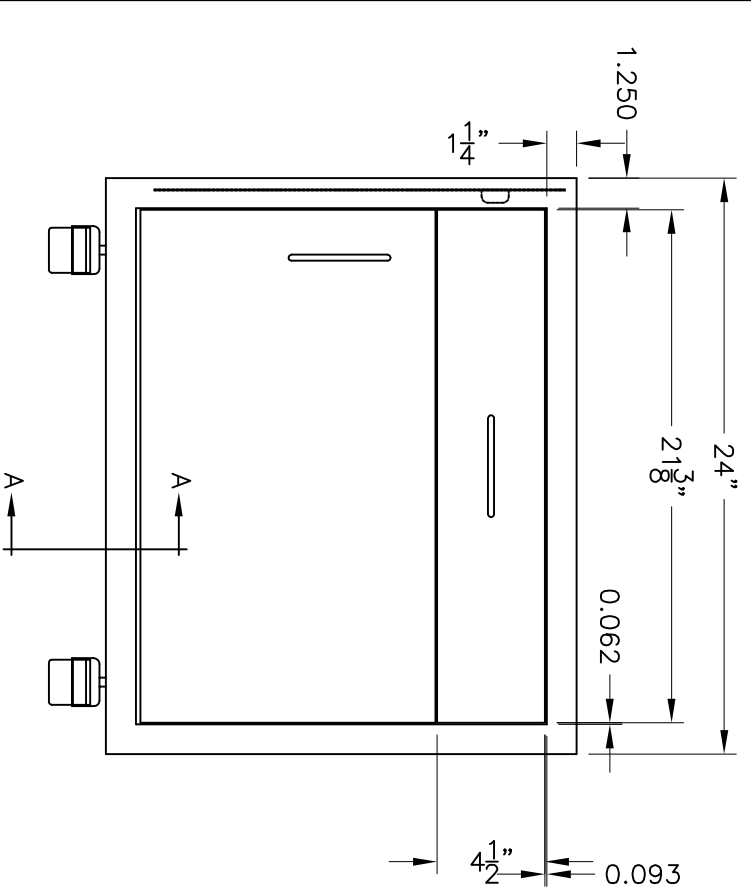

ROLLING CABINET, 1 DRAWER, 1 DOOR
24"W X 22"D X 22"H

LFS systems CORP
249 OLD CHURCHMANS ROAD
NEW CASTLE, DE 19720
PHONE: 302-322-0460
FAX: 302-322-2849

SHEET NO.	JOB NO.	CHK'D BY:	DATE	SCALE
		BJS	10-08-03	1"=1'-0"